

Mecanismo doble expulsión

COD. AS 12

CARACTERÍSTICAS

- 1 Facilidad de aplicación
- 2 Versatilidad en el uso
- 3 Bloqueo de la placa de arrastre después de la separación
- 4 Sin limite de carrera

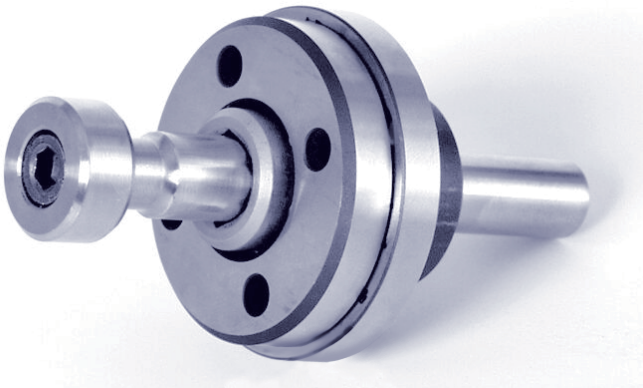
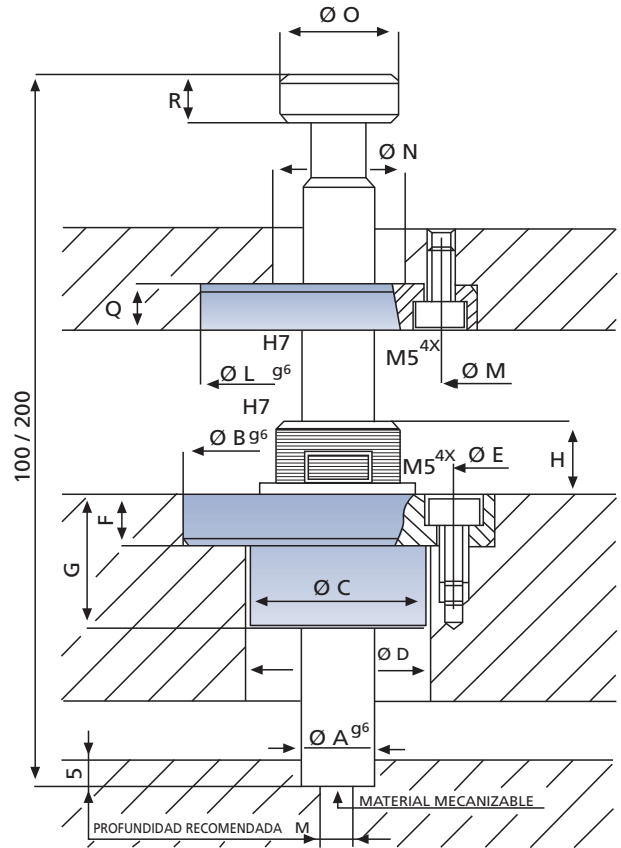

CODIGO	ØA	ØB	ØC	ØD	ØE	F	G	H	I	ØL	ØM	ØN	ØO	P	Q	R	S	Carga Máx. (Kg)
AS 12	12	50	29	29.5	38	8	21.5	12	M5	46	33	22	19.5	M5	8	9	M8	100
AS 16	16	70	41	41.5	52	13	28	17	M8	70	52	33	29	M8	13	12	M10	300

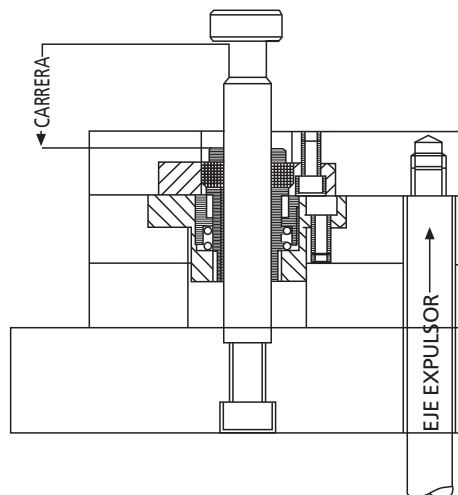
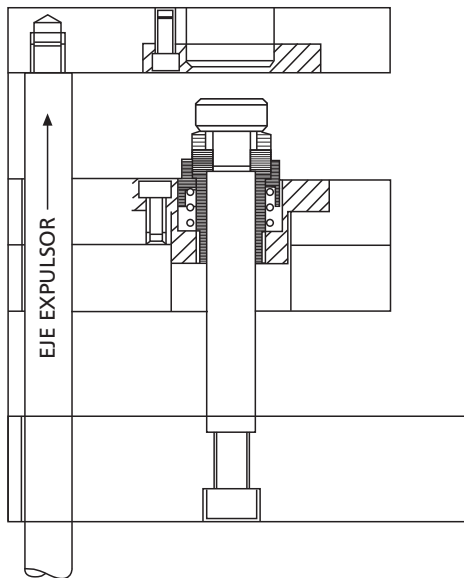

Ejemplos de aplicación del mecanismo de doble expulsión

Ejemplo instalación de doble movimiento en doble placa expulsora

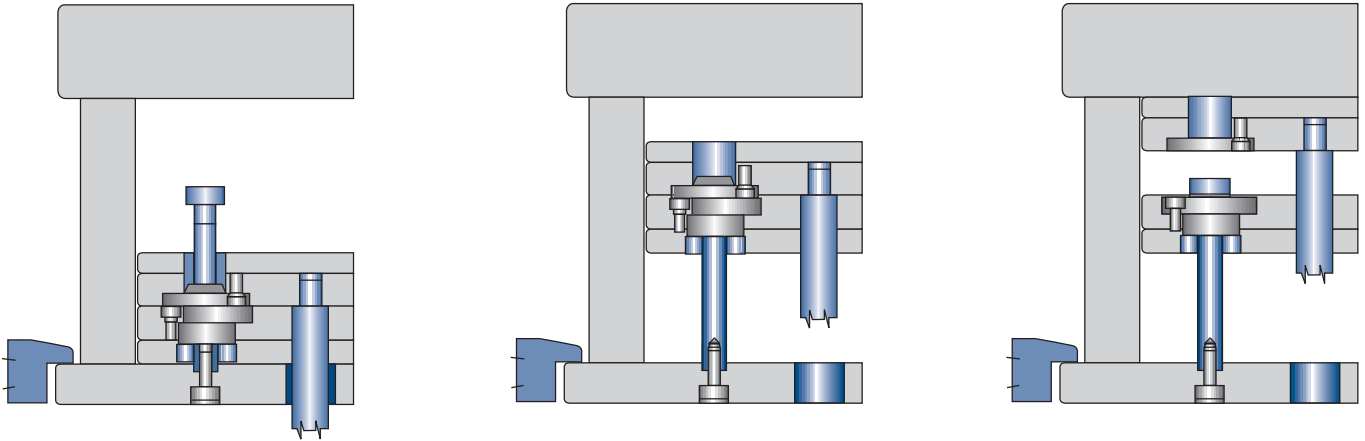

Otros ejemplos de instalación del sistema de doble expulsión

